

一般電線梱包木製ドラム寸法表

ドラムサイズ 記号及び番号	つば径 D(mm)	胴径 d(mm)	外幅 W1(mm)	内幅 W2(mm)
L3-1	520	300	400	328
-2	550			
-3	580			
-4	610			
-5	640			
L4-1	610	350	400	328
-2	640			
-3	670			
-4	700			
-5	730			
-6	760			
-7	790			
L5-1	670	400	500	428
-2	700			
-3	730			
-4	760			
-5	790			
-6	820			
L6-1	820	400	500	428
-2	850			
-3	880			
-4	910			
-5	940			
-6	970			
L7-1	910	500	600	528
-2	940			
-3	970			
-4	1,000			
-5	1,050			
L8-1	940	600	600	528
-2	970			
-3	1,000			
-4	1,050			
-5	1,100			
-6	1,150			

ドラムサイズ 記号及び番号	つば径 D(mm)	胴径 d(mm)	外幅 W1(mm)	内幅 W2(mm)
L9-1	1,100	600	750	654
-2	1,150			
-3	1,200			
-4	1,150	700		
-5	1,200			
-6	1,250			
-7	1,300			
-8	1,350			
L10-1	1,250	800	750	654
-2	1,300			
-3	1,350			
-4	1,400			
-5	1,450			
-6	1,500			
L11-1	1,400	800	900	780
-2	1,450			
-3	1,500			
-4	1,550			
-5	1,600			
L12-1	1,400	900	900	780
-2	1,450			
-3	1,500			
-4	1,550			
-5	1,600			
L13-1	1,500	1,000	900	780
-2	1,550			
-3	1,600			
-4	1,650			
-5	1,700			
-6	1,750			
-7	1,800			

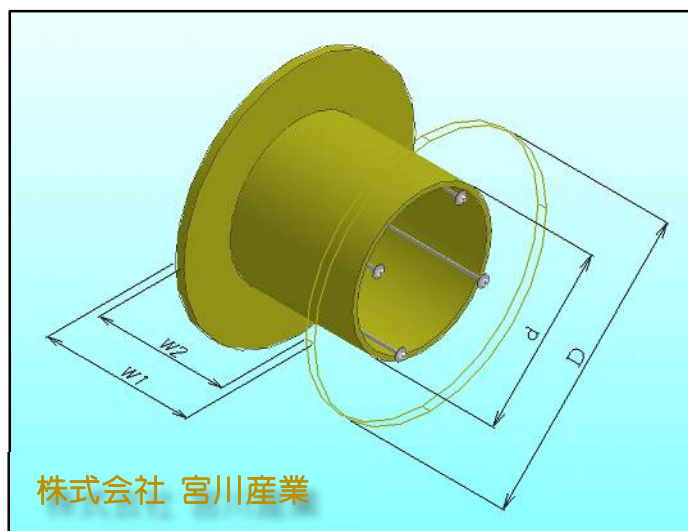

株式会社 宮川産業